



WITFOR 2005 – Building the Infrastructure

I. Executive Summary

The infrastructure commission from WITFOR 2003 stated that a valuable link exists between the power of ICT (Information and Communications Technology) and the right that people should enjoy under the Universal Declaration of Human Rights. It is well recognised worldwide that we are living in an information age and that the power of ICT promises to play an important role in improving human welfare throughout the world.

Three dominant themes define the scope of ICT: Connectivity, Capacity and Content. Connectivity refers to the underlying infrastructure that allows the linkage and continuity of information flow around the globe. Capacity deals with the efficient and effective use of the technologies and Content allows for the information and knowledge that constitute the information age and society.

Infrastructure plays a pivotal role in ICT as it provides a foundation for other technology and applications thereof. It is important to recognise that infrastructure is not limited to technology only, but embraces the other areas of services, human resources, legal & regulatory framework and economy. It is against this backdrop that we highlight the role and importance of infrastructure for accelerated development.

The WSIS plan of action calls for three important actions from an infrastructure perspective, namely support, connectivity and infrastructure. Support required an enabling and competitive environment for the necessary investment in ICT infrastructure. Connectivity refers to the provision and improvement of the connectivity for all education institutions and public access. Infrastructure calls for the development of a strengthened national, regional and international broadband network infrastructure.

WITFOR 2005 places importance on transforming the themes into tangible real undertakings, hence the focus of the infrastructure commission on a case study, an implementable project and a follow-on research proposal that may be implemented at national level of through a regional or international partnership. The case study, [Athena](#), is an R&D project funded by the European Commission and proposes the proper actions to be taken concerning the digital switchover in UHF to address the issue of broadband for all. The implementable project, [GramPatra](#), is a product of Media Lab Asia for delivery of value added digital services at places which do not have online internet connectivity. This project specifically addresses the quest for the last mile infrastructure in developing countries. The research proposal focuses on Power Line Communications (PLC) and articulates the applicability of this technology in developing countries.

The infrastructure commission examines the above undertakings with a view on their value-add towards the goal of ICT for accelerated development. The recommendations and next steps are captured within the Gaborone Protocol.



WITFOR 2005 – Building the Infrastructure

2. Commission Mandate

While industry and business are providing the infrastructure for access to information resources, as well as contents, the challenge is to define the concepts of “public domain” and “universal access” in a global context. This task should be accomplished in order to promote common public welfare while encouraging private initiative and protecting rightful economic interests.

Governments, in both industrialized and developing countries, should take action to guarantee citizens’ security, privacy and freedom of expression in the Information Society. We have to find the answers:

- ◆ What are the most important economic obstacles to access to information?
- ◆ What are the most important technical obstacles to access to information?
- ◆ How can the availability of the ICT infrastructure be guaranteed?
- ◆ How can public administrations balance the commercial interests with their civic and moral obligations to promote equitable access?
- ◆ What financial mechanisms can be put into place to ensure universal access to information?
- ◆ Should the concept of “e-rates” (preferential tariffs for educational and cultural institutions) be standardized, generalized and applied internationally to assist public service institutions and disadvantaged communities in developing countries?
- ◆ What role can the media play in facilitating the worldwide acceptance of the concept of universal access?

3. Composition

The infrastructure commission is led by three co-chairs from around the world:

Raouf Boutaba

rboutaba@bcr2.uwaterloo.ca

Dr. Raouf Boutaba is an Associate Professor in the School of Computer Science of the University of Waterloo. Before that he was with the Department of Electrical and Computer Engineering of the University of Toronto. Before joining academia, he founded and was the director of the telecommunications and distributed systems division of the Computer Science Research Institute of Montreal (CRIM). Dr. Boutaba conducts research in the areas of network and distributed systems management and resource management in multimedia wired and wireless networks. He has published more than 140 papers in refereed journals and conference proceedings. He is the recipient of the Premier's Research Excellence Award, the NORTEL Networks research excellence Award and several Best Paper awards. He is a fellow of the faculty of mathematics of the University of Waterloo and a distinguished lecturer of the IEEE Computer Society. Dr. Boutaba is the Chairman of the IFIP Working Group on



WITFOR 2005 – Building the Infrastructure

Networks and Distributed Systems, the Vice Chair of the IEEE Communications Society Technical Committee on Information Infrastructure, and the Director of standards board of the IEEE Communications Society. He is the founder and acting editor in Chief of the IEEE eTransactions on Network and Service Management, on the advisory editorial board of the Journal of Network and Systems Management, on the editorial board of the KIKS/IEEE Journal of Communications and Networks, the editorial board of the Journal of Computer Networks and the Journal of Computer Communications. He acted as the program chair for the IFIP Networking conference and the IEEE CCNC conference, and a program co-chair for the IEEE/IFIP NOMS, IFIP/IEEE MMNS, IEEE FIW, IEEE ACC and IEEE ICC symposia. Dr. Boutaba teaches computer networks and distributed systems and conducts research in the area of resource management in wired and wireless networks.

Marius W. von Wielligh

mvonwielligh@debswana.bw

Marius W. von Wielligh, Gaborone, Botswana is Head of IT for the largest diamond mining company in the world, Debswana Diamond Company. He obtained a BEng Electrical (Hons) from the University of Pretoria (RSA) and an MBL from the University of South Africa (UNISA). He is also a registered Professional Engineer (PrEng). As Head of IT for Debswana, he has huge influence over the establishment and use of ICT within the mining sector in Debswana and in Botswana.

Dorothy K. Gordon

Director-general@aiti-kace.com.gh

Dorothy K. Gordon is the founding Director-General of Ghana's first Advanced Information Technology Institute (AITI), the Ghana-India Kofi Annan Centre of Excellence in ICT (www.aiti-kace.com.gh). She is a specialist in international development with an M.Phil. from the Institute of Development Studies, Sussex, UK. As Director-General she has the responsibility of ensuring that AITI fulfils its mandate of stimulating growth of the ICT sector and the use of ICT to accelerate development in the ECOWAS sub region. AITI provides globally benchmarked IT training; works to create the right environment to stimulate high-level context-responsive ICT research and development and provides high-end consulting services to achieve global quality standards for clients.



WITFOR 2005 – Building the Infrastructure

4. Other members of the commission

Members:

- ◆ Robert Walp
- ◆ Ahmed Mehaoua, Professor at University of Versailles France, working on a major European Project focusing on the reducing the digital divide in terms of infrastructure for Eastern European countries newly joining the EC.
- ◆ Farouk Kamoun, Professor at the school of Information Technology Tunisia and former Director of the same school.
- ◆ Ramon Pujjaner, Professor at Palma University Spain and Chairman of the IFIP Working Group looking after the promotion of IT and Communications in developing countries.
- ◆ Rachid Benlamri, Professor at Dubai University Emirat Arab Unit
- ◆ Zoubir Mammeri, University Professor Toulouse – France
- ◆ Fettah Ouzani, President QoSMiC Inc., Paris – France
- ◆ Augusto Casaca, Professor INESC, Portugal



5. Case study

ATHENA: Developing Infrastructures for Broadband Access using the Digital TV Switchover

In June 2002 during the Sevilla European Council [1], Europe indicated that two major problems (among the others) have to be solved towards eEurope 2005 and beyond. The two targeted issues are (as they appear in the Sevilla document) the “**Digital Switchover**” (i.e. the transition from analogue to digital television broadcasting), and the “**Broadband access for all European citizens**” (i.e. the reduction of the digital divide between western and newly-joining eastern societies) [2].

In this context, a consortium of 12 partners from 7 European countries (France, Germany, England, Italy, Greece, Romania, and Switzerland) from industry and academia has started an ambitious research and development initiative called ATHENA (www.ist-athena.org). The partners are:

- NCSR Demokritos Project Co-ordinator (Greece),
- Ote-plus (Greece)
- Space Engineering (Italy),
- Thales Broadcast and Multimedia (France),
- Rhode & Schwarz (Germany),
- Telscom (Switzerland),
- Rundfunk Berlin-Brandenburg (Germany),
- T-Systems Nova (Germany),
- University Politechnica Bucharest (Romania),
- University of Versailles - CNRS PRiSM lab. (France),
- Centre for Technological Research of Crete (Greece),
- University of Bournemouth (United Kingdom)

ATHENA is an R&D project funded by the European Commission under the sixth framework on the Information Society Technologies priority (FP6-507312). It started on the 1st of January 2004 for 30 months duration, and proposes the proper actions to be taken concerning the Digital Switchover (DSO) in UHF, (the transition from analogue television broadcasting to digital TV) to address simultaneously the second issue “Broadband for all”. These actions are of strategic importance for the European Member Countries and most candidate ones, as the DSO arises as a possible and complementary solution towards the deployment of Broadband Access Infrastructures, especially in less favoured regions. A number of EU countries have already disposed broadband networking infrastructures, and commercial interest in satellite and cable networks have been established. However, in many other EU states, and in most Candidate Countries, the digital switchover can arise as a unique opportunity to fill the gap in the deployment of networking infrastructures.



WITFOR 2005 – Building the Infrastructure

The objective of ATHENA is the validation of a low-cost, simple-to-deploy broadband wireless access infrastructure for all citizens based on the proper reuse and upgrade of the analogue TV broadcasting system to digital one. This project will explore and validate, in several cities (i.e. Heraklion-Greece and Bucharest-Romania), the deployment/realisation of the digital switchover jointly with the design, implementation and evaluation of an IT infrastructure, which uses a regenerative DVB-T stream for the interconnection of distribution nodes, enabling access to various IP services, and digital TV programmes.

The existence of such a neutral regenerative infrastructure (DVB-T) in a city, provides not only a bouquet of television programs, but also (and most predominant) creates a powerful broadband IP backbone (the 60 available analogue UHF/VHF channels may be seen as a virtual medium that provides an aggregate bit-rate of about 1.8Gbps that covers a region of 25 kms radius. Such an approach is a possible compromise between TV broadcasters (who want the entire UHF band) and 3G telecommunication operators (who claim part of this bandwidth for exclusive use) [3]. Moreover, businessmen, or governmental bodies who are involved with the provision of IP services (e-business, e-government, e-learning, ...) will be able to set up his activity targeted to IP clients/consumers. A broadcaster will transmit his own “bouquet” of TV programmes (from his studio premises) that will be addressed to television viewers via the common DVB-T downstream, while ignoring the existence of the other service/content provider (e.g. the IP service provider) who has set up a whole IP business that is addressed to another world (IP-world) in the same city and via the same DVB-T stream. Such an infrastructure will not be a competitor to current broadcasting enterprises such as the satellite television industry, which denotes the continental or global aspect of television, but a supplementary one as it sets-off the local and regional aspect of it besides focusing in the IP capabilities that it can offer.

In such configuration, all kind of citizens/providers are co-equal users of the same infrastructure via which they access (or provide) IP services. Such implementation can be used and exploited as common infrastructure by private or public operators from the telecommunication, TV broadcasting, governmental or individual sectors having independent business plans and different users/clients.

Furthermore, this project is not only limiting its scope to individual passive users/citizens, who request predefined content/services and receive them via the UHF/TV beam, but it also provide a solution oriented to the active users/citizens. These active users may create provision and offer their own content and services to a large community by means of the availability of such a wireless metropolitan broadband infrastructure (i.e. spin-off e-businessman, e-government offices, off line and regional IP television and radio, etc.). The use of regenerative DVB-T configurations in conjunction with intermediate distribution nodes (called cell main nodes - CMNs) that utilize various broadband uplinks constitutes a converging environment capable to accommodate such a new active users/citizens.

As depicted in Figure 1, each CMN constitutes the ‘physical interface’ to the common ATHENA backbone of:



WITFOR 2005 – Building the Infrastructure

- A service/content provider.
- The users/citizens of a local network (intranet) who access the entire network indirectly via the appropriate CMN. This intranet may cover a part of the city (i.e. neighbourhood, outskirts, industrial zone, etc.) or comprise the LAN of a business centre that may be based on the IEEE 802.11x Wireless LAN technology, for example.
- The customers of a mobile network operator making use of 3G and B3G technology (i.e. UMTS).

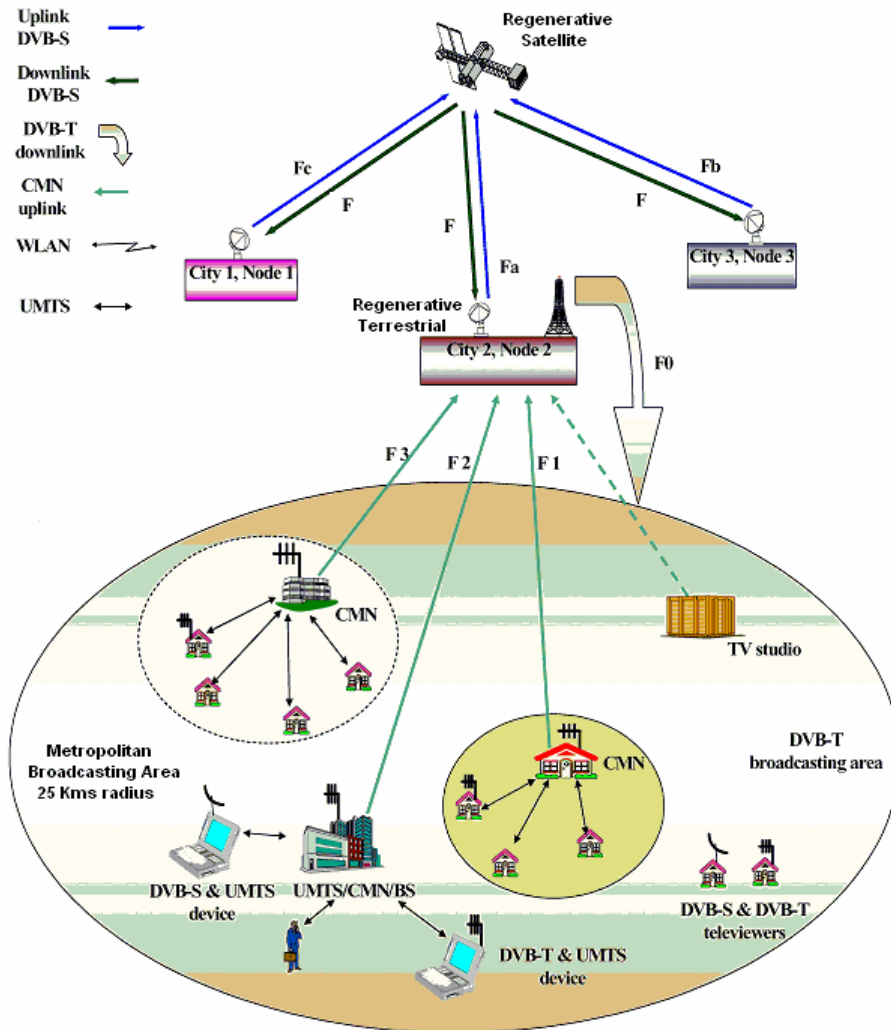

Figure 1: Interconnecting regions and citizens across Europe via the terrestrial and satellite digital television system infrastructure

Real condition trials will be utilised in a medium-sized city of a region/country with many analogue television channels/broadcasters who are investigating a viable solution in the new situation of the 'digital switchover'. Exhaustive performance evaluation tests under real condition environment will provide useful results concerning the networking potentiality of the digital television infrastructure (DVB streams) to the local and



WITFOR 2005 – Building the Infrastructure

political authorities, by notifying them about the networking dimension and the local aspect of the new digital television. Such notification will be essential prior to the decisions to be taken for the digital switchover. Such issues are currently under consideration by all European countries (“the eEurope 2005 Action Plan requires Member States to publish their switchover plans including a possible date for ending analogue television by end 2003”), which are preparing their new laws and the technical issues concerning the digital switchover.

[1] “eEurope 2005: An information society for all. An action plan to be presented in view of the Sevilla European Council, 21/22 June 2002”, Communication from the Commission to the Council, the European Parliament, the Economic and Social Committee and the Committee of the regions.

http://europa.eu.int/information_society/eeurope/news_library/documents/eeurope2005/eeurope2005_en.pdf

[2] “*Digital switchover in broadcasting*” a document created by BIPE consulting on behalf of the European Commission (Directorate General Information Society) and which was the subject for a public hearing organised by DG AI (June 2002) provided by BIPE consulting.

http://europa.eu.int/information_society/topics/telecoms/regulatory/studies/documents/final_report_120402.pdf

[3] “Study on conditions and options in introducing secondary trading of radio spectrum in European Community”, May 2004, a report carried out for the shake of RSPU by Analysys, DotEcon and Hogan & Hartson, (accessed via the

http://europa.eu.int/information_society/topics/radio_spectrum/useful_info/studies/secndtrad_study/index_en.htm



6. Implementable project – GramPatra

Copyright @ Media Lab Asia

Introduction

GramPatra is a product of Media Lab Asia for delivering value added digital services at places which do not have online internet connectivity. Digital data as letters, audio, pictures, applications, E-Governance applications such as issue of birth and death certificates, land Records, consultation with doctors / agricultural officers on health, crops diseases and other farming related information, astrology, complaint registration are some of the applications for which this can be used by rural people. An email interface has been developed which is the backbone of GramPatra for development of various applications appropriate for different rural areas.

GramPatra complements the present internet technologies to further widen the reach of digital revolution. Presently there is poor internet coverage in India and many other countries of the developing and under-developed world and hence there is poor availability of appropriate digital information access and exchange. GramPatra presents an intermediate solution for digital information access and exchange before online internet becomes available in specific geographical locations. GramPatra can be deployed quickly as no tall towers and transmissions cables etc. are required. GramPatra is a step in meeting the Universal Service Obligation for digital information access.

Components of GramPatra

The **GramPatra** technology is based on store and forward methodology. The main elements of this technology are:

- ◆ **Mobile Server**
- ◆ **Kiosks**
- ◆ **Gateway**

Digital data transfer between any two of these systems happens through high bandwidth wireless IEEE 802.11X based methods. The present system is being powered with 802.11b technology with a possible bandwidth of 11 mbps. The system will also work with other more advanced and higher bandwidth technologies like 802.11g with a bandwidth of 54 mbps.

Mobile Server

Hardware Requirements

- ◆ .net 4521 Soekris Box
- ◆ 512 MB Compact Flash Card
- ◆ Wireless LAN PC Card (802.11b) with MMCX/MCX connector
- ◆ 9 dBi Omni Antenna, 2.4 GHz with mounting hardware



WITFOR 2005 – Building the Infrastructure

- ◆ 1 watt Amplifier (2.4-2.45 GHz)
- ◆ LMR/WBC 100 Cable

Software Requirements

- ◆ Operating System – Debian Linux (v 2.4.16)
- ◆ Qmail Mail Transfer Agent

Mobile Server is a compact, low-power, low-cost, communication device based on a 133 MHz 486 class processor. It has been optimized for use as wireless router using PCCard wireless adapters. The RF-Signals are boosted (if required) through amplifier (typically 1 watt) and use an omni directional antenna (typically 8.5dBi) to extend the range further. It requires a 12 Volt D.C. supply for the operation. Mobile server can be fixed in any vehicle which has a 12 Volt D.C. battery. The Soekris Box net4521 of Soekris Engineering is used as the basic platform for the Mobile Server. This is designed to withstand high temperature (0-60 ° C) and dusty environment conditions. This device can support up to 4GB Micro drive.



Mobile Server fitted on Bus

The Mobile Server uses a 512 MB Compact Flash card for storage. A Debian distribution of Linux is installed on the Compact Flash Card and Qmail is installed on it. Qmail is used as mail transfer agent to transfer/receive mails to/from Kiosks and Gateway.

Kiosks

Hardware Requirements

- ◆ Desktop Computer (min. PIII 800 MHz)
- ◆ 802.11b Wireless LAN PCI Card (with a provision for pigtail cable)



WITFOR 2005 – Building the Infrastructure

- ◆ 18 dBi Directional/Omni Antenna, 2.4 GHz with mounting hardware
- ◆ LMR/WBC 100 Cable
- ◆ Printer (if required)
- ◆ UPS (if stable mains power is not available)

Software Requirements

- ◆ Operating System – Microsoft Windows XP
- ◆ Java Runtime Environment 5.0
- ◆ Tomcat Apache Web Server
- ◆ James Mail Server
- ◆ GramPatra Kiosk Software

Kiosks are the service nodes for the GramPatra System. The wireless services are provided through the Kiosks. A kiosk basically consists of 802.11b wireless equipped desktop computer with other accessories, which depends on the service provided. As soon as the Mobile Server, mounted on any vehicle, comes in the wireless range of kiosk, they make a wireless connection and transfer the data as emails between them. This transfer of data is made automated by the GramPatra Software at the Kiosk side as well as on the Mobile Server.

Gateway

Hardware Requirements

- ◆ Desktop Computer (min. PIII 800 MHz)
- ◆ 802.11b Wireless LAN PCI Card (with a provision for pigtail cable)
- ◆ 18i dB Directional/Omni Antenna, 2.4 GHz with mounting hardware
- ◆ LMR/WBC 100 Cable
- ◆ Printer (if required)
- ◆ UPS (if stable mains is not available)
- ◆ Internet Connection with Static IP Address (if emails provision from/to internet is required)

Software Requirements

- ◆ Operating System – Microsoft Windows XP
- ◆ Java Runtime Environment 5.0
- ◆ Tomcat Apache Web Server
- ◆ James Mail Server
- ◆ GramPatra Gateway Software

Gateway is the window to the outside world for the GramPatra network. Gateway is an 802.11b wireless equipped Desktop computer having constant internet connection with a static public IP Address. This static IP address should have DNS entries so that emails could be accepted by other email providers. All the mails to Internet as well as all the incoming mails from Internet are routed through this machine. As soon as the Mobile



WITFOR 2005 – Building the Infrastructure

Server, mounted on any vehicle, comes in the wireless range of Gateway; they make a wireless connection between themselves and transfer the data in the form of emails from the mobile server to the Gateway. Then these emails in turn are sent to internet by the Gateway. Also if Gateway has emails from internet for the kiosks, it transfers those emails to Mobile Server. This transfer of data is made automated by the GramPatra Software at both the Gateway side and the Mobile Server.

GramPatra Software

GramPatra Software is consists of three Modules. These Modules are:-

- ◆ **GramPatra Email Interface**
- ◆ **Kiosk Email Exchange Manager**
- ◆ **Gateway Email Exchange Manager**

Kiosk requires GramPatra Email Interface and Kiosk Email Exchange Manager for its functioning while Gateway requires additional Gateway Email Exchange Manager in addition to GramPatra Email Interface and Kiosk Email Exchange Manager. These modules require Apache Tomcat 5.5 or above and Apache James Mail Server 2.1.2 or above.

GramPatra Email Interface

GramPatra Email Interface is a web based interface. This is further divided into two parts: Configuration Module and Email Module. Configuration module is for the administrators to keep track of all the settings of GramPatra Network. User Module provides a minimal set of email features for composing, viewing and other email related operations. This requires Apache Tomcat or any J2EE compliant web server for hosting.

We are using Apache Tomcat 5.5 as the web server. The various features provided are:-

- ◆ The GramPatra System was initially developed as single user system at the kiosks. The multi user support is under development.
- ◆ The GramPatra is Unicode compliant and currently available in two languages: Hindi and English. It is possible to develop for other languages easily.
- ◆ The GramPatra System currently provides three folders: Inbox, Outbox and Sent
- ◆ Mails for storing incoming mails, spooled mails and sent mails respectively.
- ◆ The GramPatra system allows up to three attachments with an email. This can be increased if required.
- ◆ A minimal Address Book feature is provided. User can add and delete entries from Address Book but cannot modify existing entry.
- ◆ Provides an interface for making the setting for the GramPatra Network.



WITFOR 2005 – Building the Infrastructure

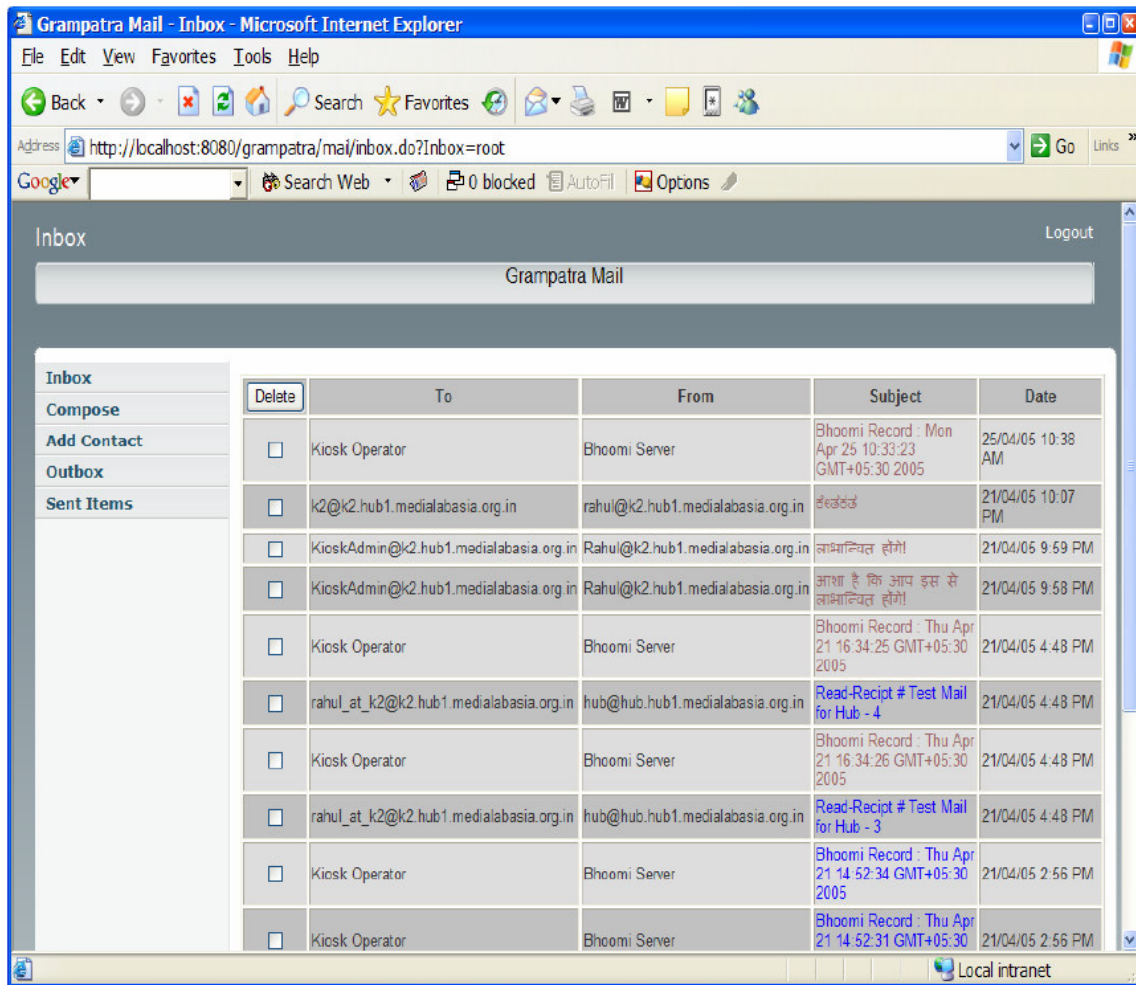

Kiosk Email Exchange Manager

The Kiosk Email Exchange Manager runs in the background and it is not visible to the user. Wireless Email Exchange Manager keeps waiting for the Mobile Server. As soon as it receives any signals from the Mobile Server, it first ask the Mobile Server to start the transfer of emails it has for the kiosk and then if it has any mails to send to any kiosk or outside world, it transfers those mails to Mobile Server. This is automatic in nature and requires no user interaction.

Gateway Email Exchange Manager

The Gateway Email Exchange Manager runs in the background and it is not visible to the user. This is responsible for the interaction of the GramPatra Software with outside world. It forwards all the emails the system receives from internet to the respective kiosks. It also forwards all the emails the Gateway receives for sending to internet from the kiosks. This is automatic in nature and requires no user interaction.



WITFOR 2005 – Building the Infrastructure

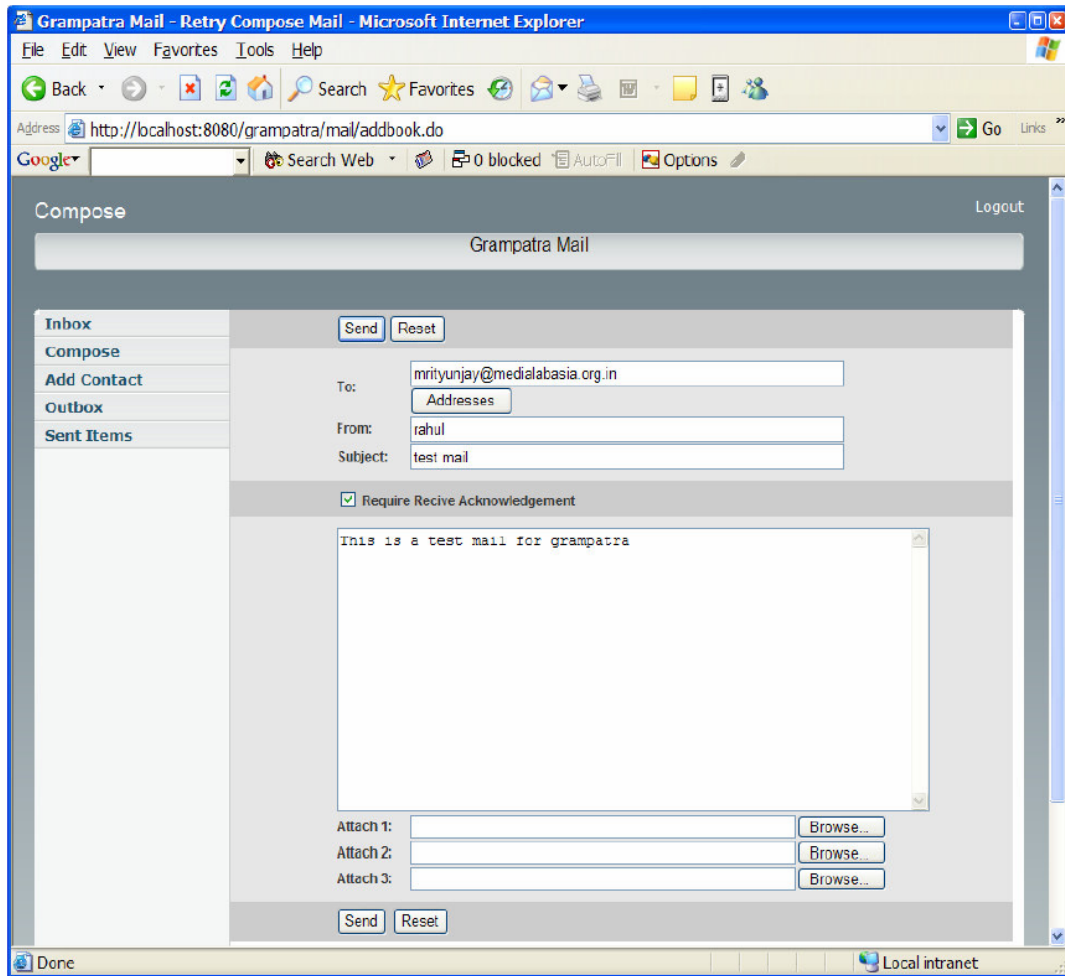

Technology used in GramPatra

The GramPatra technology works on store and forward methodology based on SMTP protocol. The elements of GramPatra system -Kiosks, Mobile Server and Gateway, are IEEE 802.11X wireless equipped. Digital data transfer in the form of emails between any two of these systems happens through high bandwidth wireless IEEE 802.11X based methods.

Mobile Server is a moving component in the system and the other two components - Kiosks and Gateway are stationary. In the ad-hoc wireless network, whenever a wireless device comes within the wireless range of other devices, they can create an ad-hoc network and communicate with one another. GramPatra System exploits this property.

Mobile Server travels from one kiosk to another and transfers digital data as soon as it comes in wireless range of the kiosk. And when it reaches Gateway, Mobile Server transfers the digital data to Gateway which in turn can send the digital data to Internet.



WITFOR 2005 – Building the Infrastructure

Mobile Server also makes sure that if some emails have to be sent from one kiosk to another, then these emails need not to go through the Gateway as these can be delivered directly from one kiosk to another. Gateway receives the emails from Internet for the kiosks and then forwards them to the Mobile Server which in turns delivers to Kiosks. In this way, we create a network in which Mobile Server act as the communication medium between the kiosks and the Gateway.

The present GramPatra system works with 802.11b wireless technology with a possible bandwidth of 11mbps. The system can also work with other wireless technologies like 802.11g with a bandwidth of 54mbps.

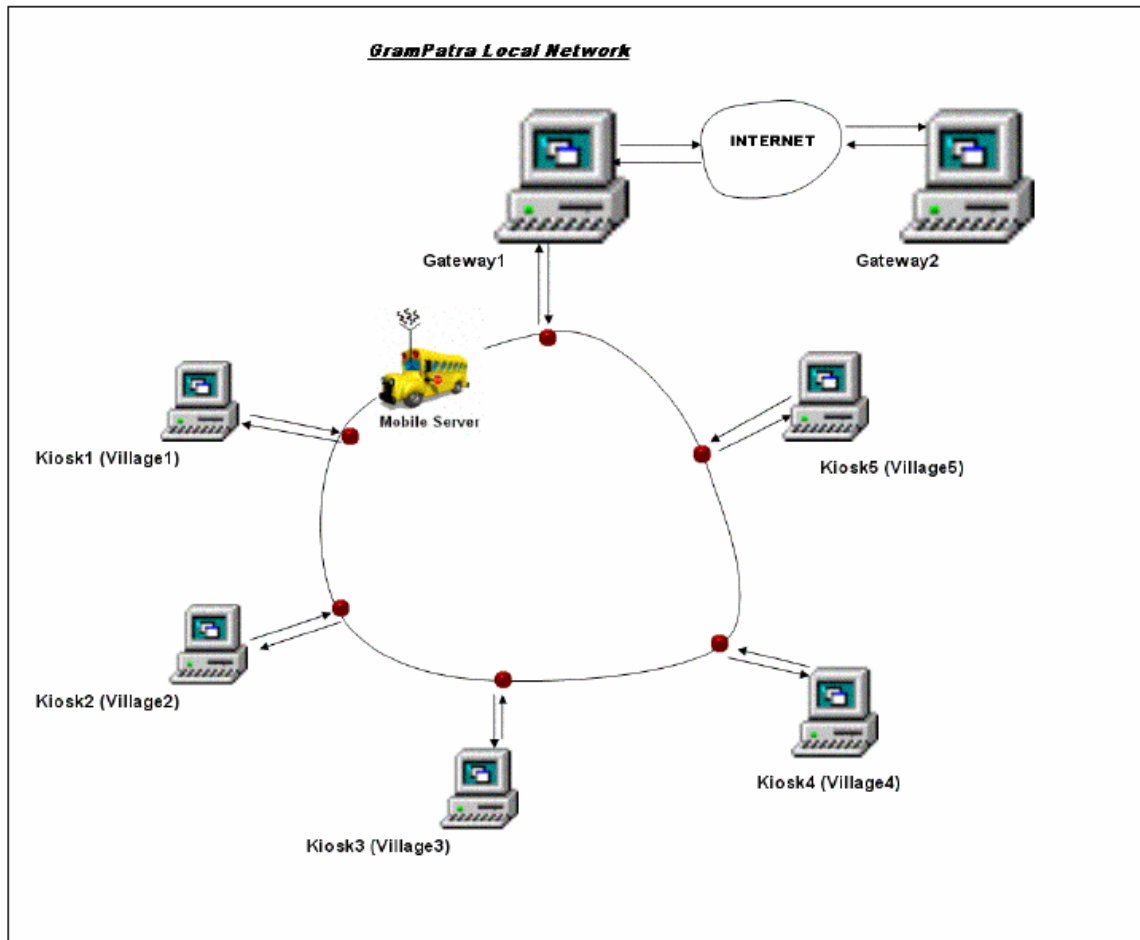

Local GramPatra Network

Local GramPatra Network

More than one GramPatra local networks can connect to one another and to the internet to form a GramPatra global network.

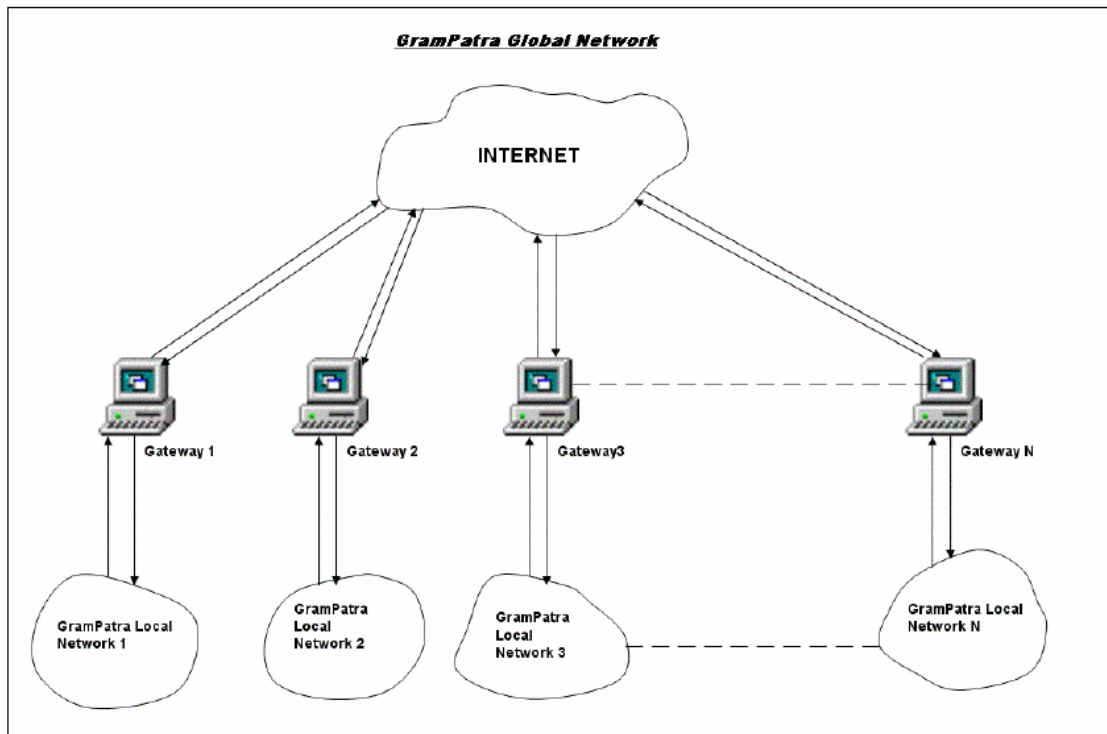

Global GramPatra Network

Implementation: Bhoomi-GramPatra Project

A pilot project between Media Lab Asia, Govt. of Karnataka and National Informatics Centre called “Bhoomi-GramPatra” is operating for the delivery of land record documents to the people in remote villages of Karnataka. In this project, Mobile Server is fitted on a public transport bus which traverses in a specific route. The requests for the land record documents are generated at the kiosk in the villages which are picked up by mobile server in the bus while it passes near the kiosk and are transferred to Bhoomi Server at Doddaballapur town when the bus passes near the Gateway system near the Bhoomi server. The requests are processed by Gateway system to automatically retrieve the corresponding land record documents form the Bhoomi Server which are then picked up by the mobile server when it next passes the Gateway system and transfers to the respective kiosk as email attachments. The land record documents are then delivered to the villagers by the kiosk operator.

Contact Information:

Dr. G.V. Ramaraju,
Media Lab Asia,
C-235, 1st floor, Defence Colony,
New Delhi, India 110024.
Email: ramaraju@medialabasia.org.in
Tel: 091 11 51553693, Fax: 091 11 51553689



7. Research proposal

Powerline Communication Systems – (1), (2)

Powerline Communication Systems use the existing AC electrical wiring as the network medium to provide high speed network access points almost anywhere there is an AC outlet. In most cases, building a home network using the existing ac electrical wiring is easier than trying to run wires, more secure and more reliable than radio wireless systems like 802.11b, and relatively inexpensive as well. For most home and small office applications, this is an excellent solution to your networking problems.

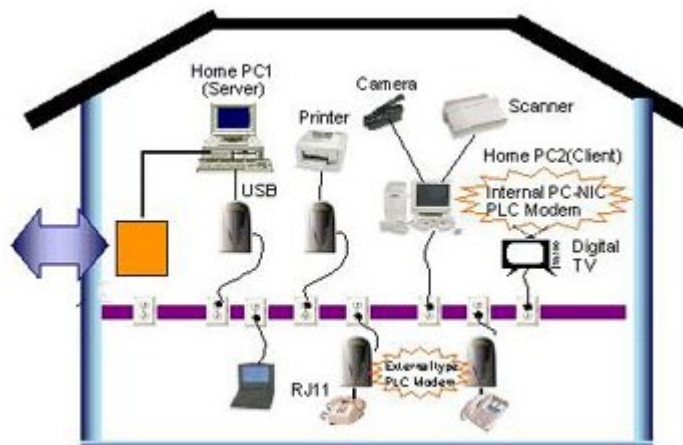

Introduction

Connecting to the Internet is a fact of life for business, government, and most households. The lure of e-commerce, video on demand, and e-mail has brought 60 million people to the Internet. Once they get to the Internet, they find out what it's really like. That includes long waits for popular sites, substantial waits for secure sites, and horrible video quality over the web. Nonetheless, Internet users persevere.

Industry Overview

However, the companies who provide Internet services have not been carrying on as usual. They realize that users of the Internet are hungry for faster service than phone lines and 56k modems currently provide. Additionally, many Internet service companies seek to increase their profitability by offering Internet access, local phone calls, cable TV, and perhaps long distance phone services to their customers in one relatively inexpensive package. The solution is a high bandwidth network with links to each customer's location. Implementing this type of network has not proven to be easy.

Telephone companies have offered high bandwidth lines for many years. For the most part, the cost of these lines and the equipment needed to access them has limited their usefulness to large businesses. The lone exception has been ISDN (Integrated Services



WITFOR 2005 – Building the Infrastructure

Digital Network) which has won over some residential customers. ISDN offers fast Internet access (128k) at a relatively low cost.

Telephone companies have begun to replace the phone lines that connect residences and business to the standard telephone network with higher bandwidth lines. However, this process is costly and time consuming. Such higher bandwidth networks won't be operational for several years.

Cable television companies have also jumped into the Internet access market. The lines that carry cable television are much faster (1500k) than standard phone lines or even ISDN. The major problem with cable TV's attempts at providing Internet access has been the unidirectional character of cable TV lines. Cable TV lines are only designed to bring information to the customer, not to get input from the customer. This fundamental flaw in cable TV lines has increased the costs of developing Internet access services based on them. Thus, most cable TV Internet access systems will not be ready for several years. (Currently, Internet access over cable TV lines is available, but a phone line handles messages from customers to the Internet.)

Wireless solutions have also been proposed, but have run into problems. First, the performance and reliability of wireless solutions has not been up to the level of any of the wire-line solutions described so far. Second, the ability to send data from a customer to the Internet requires much more equipment than simply receiving data. This additional equipment makes wireless Internet access much more expensive than wireless cable TV.

A Solution

None of the available Internet access services offer the right balance of cost, convenience, and speed. Digital PowerLine technology could change all that. It gives customers high speed Internet access through electrical networks. Lower costs are achieved because the service is implemented on standard electrical lines. The service is also convenient because it's already in your home. Internet access through Digital PowerLine would be at 1Mbps, 20 times faster than a standard phone/modem connection.

Most high bandwidth Internet access schemes fail at the point of connection to residences and businesses. The cost of connecting many individual points usually overwhelms the project. Digital PowerLine services are already connected to almost all residences and businesses through electrical lines, thus making the service more economical for both providers of the service and customers of the service.

Using electrical lines also makes the service very convenient. There is no need for the bulky apparatus associated with wireless access. The service does not tie up phone lines like standard phone/modem connections, current implementations of Cable TV services, or other phone line based services. Additionally, the system features constant access to the Internet and much of the apparatus is already in your home.



WITFOR 2005 – Building the Infrastructure

Digital PowerLine offers very high speed Internet access. Its performance far outclasses phone/modem connections and even ISDN. At 1Mbps, customers of Digital PowerLine services could explore the Web, talk on the phone, and watch a video-on-demand movie at the same time. All of these services are available through the innocuous looking electrical lines currently in your home. Evidently electrical lines were manufactured with more forethought than phone lines.

Overview of Technology

Digital PowerLine, developed by Northern Telecom and United Utilities, is capable of transmitting data at a rate of 1Mbps over existing electricity infrastructure.

Through "conditioning" of the existing electricity infrastructure, electrical utilities can transmit regular low frequency signals at 50 to 60Hz and much higher frequency signals above 1MHz without affecting either signal. The lower frequency signals carry power, while the higher frequency signals can transmit data.

Digital PowerLine use a network, known as a High Frequency Conditioned Power Network (HFPCN), to transmit data and electrical signals. A HFPCN uses a series of Conditioning Units (CU) to filter those separate signals.

The CU sends electricity to the outlets in the home and data signals to a communication module or "service unit". The service unit provides multiple channels for data, voice, etc.

Base station servers at local electricity substations connect to the Internet via fibre or broadband coaxial cable. The end result is similar to a neighbourhood local area network.

The Server

The Digital PowerLine base station is a standard rack mountable system designed specifically for current street electricity cabinets. Typically, one street cabinet contains 12 base station units, each capable of communicating over 1 of 40 possible radio channels. These units connect to the public telecommunications network at E1 or T1 speeds over some broadband service.

Several options, with different costs, can provide broadband Internet service to each base station. The simplest solution is connecting leased lines to each substation. This solution is potentially quite costly because of the number of lines involved. A wireless system has also been suggested to connect base stations to the Internet. This option reduces local loop fees, but increases hardware costs. Another alternative involves running high bandwidth lines, along side electric lines, to substations. These lines could be fibre, ATM, or broadband coaxial cable. This option avoids local loop fees, but is beset by equipment fees. The actual deployment of Digital PowerLine will probably involve a mix of these alternatives, optimized for cost efficiency in different areas and with different service providers.



WITFOR 2005 – Building the Infrastructure

These base stations typically serve approximately 50 customers, providing over 20 MHz of usable spectrum to near end customers and between 6 and 10 MHz of useable spectrum to far end customers. The server operates via IP to create a LAN type environment for each local service area.

The HFCPN Conditioning Unit

The Conditioning Unit (CU) for the Digital PowerLine Network is placed near the electric meter at each customer's home. The CU uses band pass filters to segregate the electricity and data signals, which facilitate the link between a customer's premise and an electricity substation.

Conditioning Unit

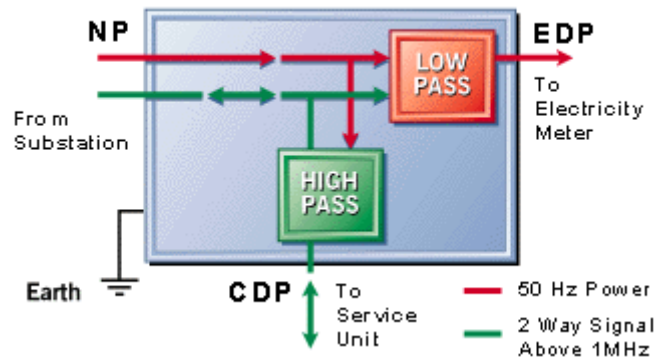

The CU contains three coupling ports. The device receives aggregate input from its Network Port (NP). This aggregate input passes through a high pass filter. Filtering allows data signals to pass to a Communications Distribution Port (CDP) and a low pass filter sends electric signals to the Electricity Distribution Port (EDP).

The 50 Hz signal flows from the low pass filter, out of the EDP and to the electricity meter. The low pass filter also serves to attenuate extraneous noise generated by electrical appliances at the customer premises. Left unconditioned, the aggregation of this extraneous noise from multiple homes would cause significant distortion in the network.

The high pass filter facilitates two way data traffic to and from the customer premise. Data signals flow through the CDP to the customer's service unit via standard coaxial cable.

Service Unit

The service unit is a wall or table mountable multi-purpose data communications box. The facilitates data connections via BNC connectors cable modems and telephone connections via standard line termination jacks.

The service unit provides its own line power for ringing and contains a battery backup in case of power outage. Alternative Differential Pulse Modulation (ADPCM) is used for speech

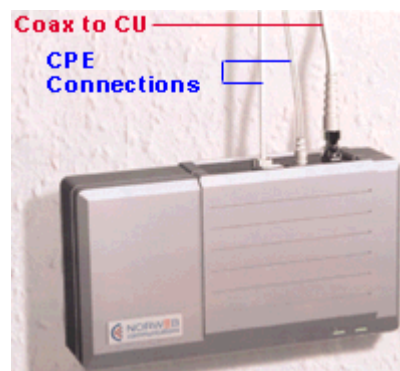

unit
to

Code



WITFOR 2005 – Building the Infrastructure

sampling.

Because Digital PowerLine allows for the termination of multiple radio signals at the customer premises, the service unit can facilitate various Customer Premise Equipment (CPE) simultaneously. In a manner similar to ISDN, data (computers) and voice (telephones) devices can coexist without interfering with each other.

Potential Advantages of Digital PowerLine Technology

This telecommunications model has multiple advantages over others including speed, an established local loop, and dedicated connections. These advantages make Digital PowerLine technology an attractive alternative for telecommunications systems.

In the Digital PowerLine model, small LANs are created; they terminate at each local electricity substation. These LANs will share a T1/E1 connection to the Internet, similar to a corporation leasing a T1 line. Individual users should experience tremendous speed increases over conventional 28.8kbs or 56kps dialup connections, even at peak usage.

Another inherent advantage to the Digital PowerLine model is the fact that it works well over the existing electric power infrastructure (at least in the UK, see the Limitations section below). Only the substation server equipment and customer conditioning/service units need to be installed in order to establish a Digital PowerLine network.

Dedicated, multipurpose communication lines make the Digital PowerLine model an attractive option for the information age. Wide bandwidth and frequency division multiplexing allow for multiple lines to a single household. Ideally, an entire family could utilize their own communication devices simultaneously, whether telephone or PC, without interrupting one another.

Potential Extensions to Digital PowerLine Technology

There are many possible extensions to the Digital PowerLine model. Those mentioned in reviews and technical journals include "the wired home" and remote customer information services.

Since Digital PowerLine creates a LAN type environment by running IP, people could theoretically control all of the appliances in their home from their PC or a remote device. Each home on the neighborhood LAN would operate as a sub-network of the LAN and each electrical outlet could be treated as a node on that sub-network.

The Nortel web site predicts, "It could also be feasible to have an Internet address for every plug in the house, through which you could e-mail, for example: 'fridge@home' and study the picture relayed by the video camera to see what shopping you require; or you could remotely turn the lights off and the burglar alarm on using your own password."



WITFOR 2005 – Building the Infrastructure

Remote services such as remote metering have already been tested under this model and many more services are possible. Because the service provider can keep track of electricity and bandwidth usage via the network, customers will also be able to monitor their usage, reliably predict billing and keep an eye on household usage (i.e. the teenager's phone usage).

Current Limitations of Digital PowerLine Technology

Several implementation issues have held back Digital PowerLine in North America and the UK. Respectively, the problems are the numbers of users per transformer and the size and shape of light poles.

In North America, a transformer serves from 5 to 10 households while in Europe a transformer serves 150 households. Digital PowerLine signals cannot pass through a transformer. Therefore, all electrical substation equipment needed for Digital PowerLine has to be located after the transformer. Since there are fewer households per transformer in North America, predicted equipment costs are prohibitive. However, this conclusion has been debated. Analysts suggest that 100% subscription rates are possible in the US, and that at such rates Digital PowerLine is profitable. Conventional wisdom suggests that there is a way to make Digital PowerLine profitable in North America, whether it is through bundling a variety of services or higher fees.

Soon after the first trials of Digital PowerLine in the UK, some unanticipated problems arose. Certain radio frequencies were suddenly deluged with traffic, making it impossible to transmit on those frequencies. BBC, amateur radio, and the UK's emergency broadcasting service were affected. The apparent culprits were standard light poles. Then it became clear that by pure chance British light poles were the perfect size and shape to broadcast Digital PowerLine signals. This situation posed problems not just because of the frequencies involved but also because anyone could listen in on the traffic. Nor.Web is addressing the problem by proposing to lease the frequencies involved from their owners and offering amateur radio operators a new frequency. Negotiations on this topic are currently taking place in London. The privacy issue has not been fully addressed at this point, besides suggestions that all sensitive information should be encrypted.

The Market for Digital PowerLine

Trends in both the electric and telecommunications industry have lead to a climate where Digital PowerLine should be a big player. These trends include customer demand for affordable and high speed Internet access, deregulation of electrical utilities, and the repercussions of a variety of telecommunications legislation.

Customers want cheaper, faster, and more reliable access to the Internet right now. Not only can Digital PowerLine provide that type of service, but it will be available before other broadband access technologies. Therefore Digital PowerLine has both a time to market and cost advantage. This may be too much for the other broadband access technologies.



WITFOR 2005 – Building the Infrastructure

The utility industry is facing deregulation in North America, Europe, and some parts of Asia. Deregulation means increased competition in the slow growing electricity market with little protection for utilities. Consequently, many utilities are actively seeking to diversify into other, more profitable, industries. For many utilities telecommunications and Internet services have been a sensible choice. That option can only become more popular as Digital PowerLine matures.

Digital PowerLine offers a deregulated utility several options and advantages. The utility can either lease the rights to implement Digital PowerLine on its electrical grid or develop the technology itself. The advantages include the low cost of the local loop, differentiating the utility from other utilities, and bundling a variety of services.

The most recent telecommunications act has tried to make it easier for all types of telecommunications firms to sell local services and long distance services. However, Regional Bells actually have control over local lines and charge other companies who place calls on their lines. Many of the larger phone companies have sought to get around these charges by building or leasing their own networks to connect to local points. Digital PowerLine is an existing network that fits those needs. Expect to see smaller telecommunications companies partnering with electrical utilities to provide alternative local phone service.

Conclusion

Digital PowerLine technology is an exciting alternative to connecting to the Internet via phone and modem. Though this technology is not commercially available yet, it should be available before other broadband technologies due to the relatively low cost of its local loop. Moreover, its high speeds will provide Internet access, video on demand, local phone, and long distance phone services to customers.

It is the aim of the commission to raise interest in this technology with a view on initiating research into the use and applicability of powerline technology in developing countries with a view on providing the last mile infrastructure.

[1] “Powerline Carrier (PLC) Communication systems”, Khurram Hussain Zuberi, September 2003, http://www.it.kth.se/~iw01_zkh

[2] “Powerline communication systems” - <http://www.ipcf.org/powerlineintro.html>